

# Jozef Stefan Institute, Ljubljana, Slovenia

Department of Systems and Control

Jamova c. 39, 1000 Ljubljana, Slovenia

[www.ijs.si](http://www.ijs.si), [dsc.ijs.si](mailto:dsc.ijs.si), phone.: +386 1 477 3798



## Project idea: **Zero defect production of rotational devices**

### Basic description

The presented project idea is in line with the topic **HORIZON-CL4-2021-TWIN-TRANSITION-01-02: Zero-defect manufacturing towards zero-waste**. The main objective is to approach zero defect production of rotational devices (e.g. electromotors, gearboxes, robot arm drives, etc.) by implementing two technologies: 1. Advanced end-of-line quality inspection, and 2. Advanced control and supervision of the whole production line.

**1. End-of-line quality inspection system (EOL QI)** will inspect the quality of produced devices in a **non-destructive** manner, i.e. by measuring (i) conventional characteristic variables (electric parameters, torque, etc.) and also (ii) additional characteristic variable (sound, vibration, etc.) during short predefined test run of each produced device. Both types of raw measured variables will be a subject of advanced data processing, followed by feature extraction and finally, fault detection and isolation. **Artificial intelligence based feature extraction methods** will define the produced device quality and draw attention to possible shortcomings/errors in the production process that can lead to non-zero defect production or can shorten predicted device lifetime.

Timely detection of faults or shortcomings in a production process is extremely important since it prevents faulty devices to be delivered to customers and built into appliances. Classification of possible shortcomings in a production process is equally important since it provides the possibility of identifying faulty workstations in a production process and repairing them. In both cases, waste of material, energy, labour and time is minimized.



Example of an electric motor –  
subject of zero-defect manufacturing



Conventional end-of-line quality inspection system

**2. Advanced control and supervision of the whole production line** is aimed at finding causes of shortcomings/errors detected by End-of-line quality inspection system. In this way, detection or forecast of possible faults already at early stage during production steps enable timely action or

servicing of the individual workstations before the final product (e.g. electric motor) is fully assembled (and material, energy and time wasted).

In general, faults during production process can occur due to faulty material, faulty components and due to deviations in production process. For example, excessive force during bearing insertion in an electromotor stator may indicate inadequate housing geometry and usually result in increased rotational friction of the produced motor, excessive energy consumption and increased vibration, which is detected during end-of-line quality inspection.

To be able to predict or detect faults in early stage during production steps, it should be known/identified, how variables (parameters) of production workstations (e.g. bearing insertion force and many others) affect final product quality. In addition, characteristic data of input material and components should also be considered and traceability of material and components during production should be assured.

The relation between production parameters, components and material on one side and product quality on the other side will be identified by advanced AI based methods (machine learning and root cause analysis), which will be performed on datasets acquired from production workstations and end-of-line quality inspection system. Once the relation is known and relevant digital twin model is designed, it will be possible to detect/predict product faults and identify low quality product, based on the assembly machine data well before the product is finalized.

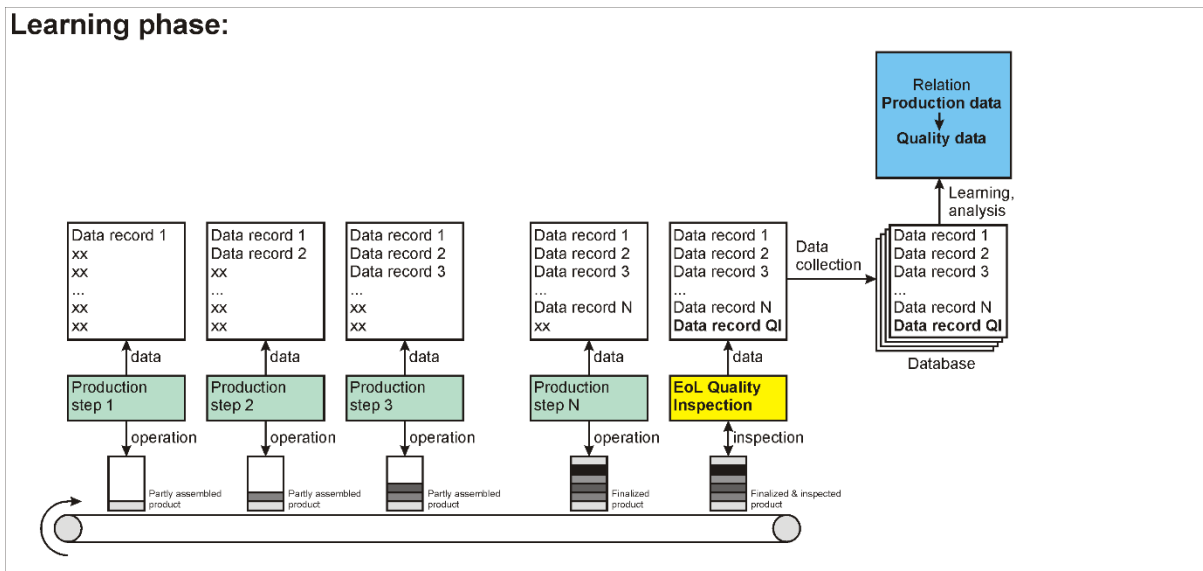

## Exploitation phase:

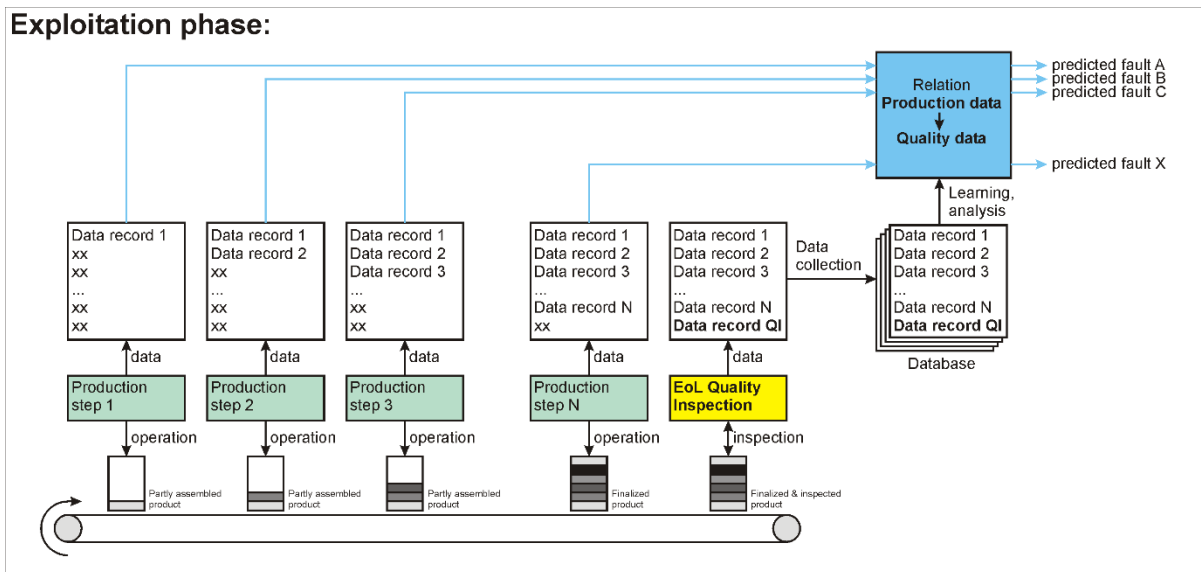

## Current status

The technology of conventional end-of-line quality inspection of electric motors has been developed by project partners and proven in industrial environment for several years. It is based on standard signal processing methods. Advanced control and supervision of whole production line is not yet implemented.

## Innovation

The existing concept of end-of-line quality inspection will be re-engineered and upgraded to meet several goals:

- Increase the reliability, which strongly depends on the quality and consistency of measured data. Low quality of measured data and erroneous measurements may lead to wrong diagnosis. A methodology will be developed to estimate the quality and consistency of measured data by different kinds of algorithms, based on advanced statistical analysis, modelling and machine learning.
- Increase reconfiguration capabilities to be able to process different subtypes of products without major modification of the inspection system.
- Implement the ability of self-tuning of fault decision thresholds based on statistical distributions of product quality indicators,
- Implement advanced monitoring of product quality indicators over a selected period of time to detect quality-related trends of production line and to study the influence of input material, components, suppliers and other factors to the product quality.
- Implement in-line inspection system that will identify faults and/or low-quality products already in early stages of production process.

Advanced control and supervision of whole production line will be implemented and based on innovative machine learning, data mining and modelling technologies to explore relations between production parameters, material and component parameters (inputs), and final product quality parameters (outputs). Knowing and understanding the relation is a prerequisite to prevent faults and control the quality.

## Addressing expected outcomes required by the call topic

Expected outcome:	The way how proposed project address the expected outcome:
Demonstrate a significant increase of sustainable production through improved control systems and non-destructive inspection methods.	The project will provide a non-destructive quality inspection method at the end of production line of case-study rotational devices, namely electric motors and quality control by supervision of parameters of production line.
Develop methodologies and tools to prevent the generation of defects at component level and its propagation to the system level.	<p>The project will provide the methodology of prediction and detection of faults at early production steps, well before the device/motor is assembled.</p> <p>On the other hand, electric motor always represents a component of the particular appliance. Finding the fault at the motor component or at the assembled motor will prevent propagation of fault to the appliance (system level).</p>
Create new diagnostic methods for in-situ monitoring of industrial production.	The project will provide a method for monitoring the entire production line. Based on production machine parameters it will be possible to predict faults and make corrective actions. Such new diagnostic approach will learn diagnostic logic by combining non-invasive end-of line inspection data and linked process and material variables.
Ensure efficient use of materials, repair strategies, and reduced production cost and time.	<p>Quick detection of faults in early production steps stops the production of potentially faulty electric motor.</p> <p>Detecting the faulty electric motor at the end of the production line prevents its delivery to the customer and its integration to the final appliance.</p> <p>In both cases, waste of material, energy, time and labour is prevented/reduced.</p>

## Partner description



[Jozef Stefan Institute \(JSI\)](#) is the leading scientific research and development organization in Slovenia (staff of about 1000) covering a broad spectrum of disciplines: physics, chemistry, electronics, automation and information technologies, nuclear reactor engineering and energetics.

[Department of Systems and Control](#) directly involved in this project proposal works mostly on applied research, development of control systems, and transfer of knowledge into industrial applications. Within this framework the following research areas are assessed and products are being developed: advanced methods and algorithms for automatic control, procedures and software tools for design

and implementation of control systems, process modelling for process control, optimization and diagnostics, smart factories, process diagnostic and condition monitoring, design and implementation of specialized measurement and control electronic modules for various applications. The mission of the department is a transfer of research results into industrial practice. In this way, we completed a number of control-oriented projects for industrial sector (chemical, steel, electric motor production, district heating, fuel cells, hydrogen technologies, etc.).

The Department currently coordinates two international projects: INEVITABLE (H2020-SPIRE) and REACTT (H2020-FCH JU).

Moreover, the department has an already established collaboration with the industrial partner Domel. Several conventional End-of-line quality control solutions were developed and integrated within the Domel production line.

**DOMEL**<sup>®</sup> Domel, d.o.o. is a global development supplier of electric motors, vacuum motors, blowers and components. The dedication to innovation has positioned Domel as a driving market force in several key technology areas such as universal vacuum motors, brushless DC blowers, brushless DC motors, including ultra-premium efficient permanent magnet synchronous motors. Domel is a worldwide development leader in the vacuum motor market and takes an active part in the business of cleaning technology, ventilation systems, industrial and laboratory applications, automotive industry, medicine and e-mobility. Domel follows the mission statement of “being socially responsible company” (<http://www.domel.com/company/vision-mission-values>). Due to high quality and safety standards of electromotor this industry, further growth is needed in order to maintain global competitiveness. Domel decided to retain a high level of competence, learning, innovation, responsibility and self-confidence, considering these values as the most important for the fulfilment of its quality and business standards. His manufacturing units are certified according to ISO 9001, ISO 14001, ISO 13485 and ISO/TS 16949 for automotive industry.

Domel is oriented towards special applications where advanced technologies are needed. Domel contributes to the quality of finished products by providing an extra-long lifetime, very low noise and proven ultra-high efficiency, thereby reducing energy consumption for the end-user. With this, we contribute to sustainable economic growth and a green future.

By now, Domel’s motors power over 300 million devices worldwide in premium and consumer markets.

## Contact person

dr. Gregor Dolanc, Head of Department  
Jozef Stefan Institute  
Department of Systems and Control  
Jamova 39, 1000 Ljubljana, Slovenia  
tel.: +386 1 4773 798  
e-mail.: gregor.dolanc@ijs.si